



POSITIVE SINUSOIDAL DISPLACEMENT PUMPS SN series



Positive displacement pumps with gentle handling of the product thanks to the shape of the rotor and the working without any product slip and death zone. Very high efficiency, excellent suction capability and constant performance even with products having range of viscosities.

The positive sinusoidal displacement pumps have many advantages: extremely gentle product transfer and excellent suction capability, continuously open inlet, no foaming of the pumped product, compact design, dry running, possible for a short period, and nearly all main wearing parts can be exchanged inline, without disconnecting the inlet and outlet pipes.



*Pump in 316 stainless steel with internal front bush, liners and scrapergate made from polymers. O-rings in EPDM or FKM.
A wide choice of materials and motorization options to suit customers' application and product requirements.
All the materials are FDA certified.*

PRODUCTS AND PROCESSES

Products

Low and high viscosity liquids; Cremes, Lotions, Products for the fine chemical and pharmaceutical industry, nearly all thin and thick liquid food products with or without particles. Products with a low abrasive content.

Typical pumpable products

Food industry: juices, fruit concentrates, beverages, syrups, alcoholic beverages, waters etc., diced tomatoes, cooked vegetables in pieces, fruit salads, soups and other food products, delicatessen salads, chocolate and creams.

Dairy industry: processed cheese, yoghurt, whey, ricotta cheese, cheese curd of all kinds, Butter.

Fine Chemicals and Cosmetics: cosmetic products, cremes, gel, shampoo, toothpaste, body lotions, cleaning liquids, paints and coatings.

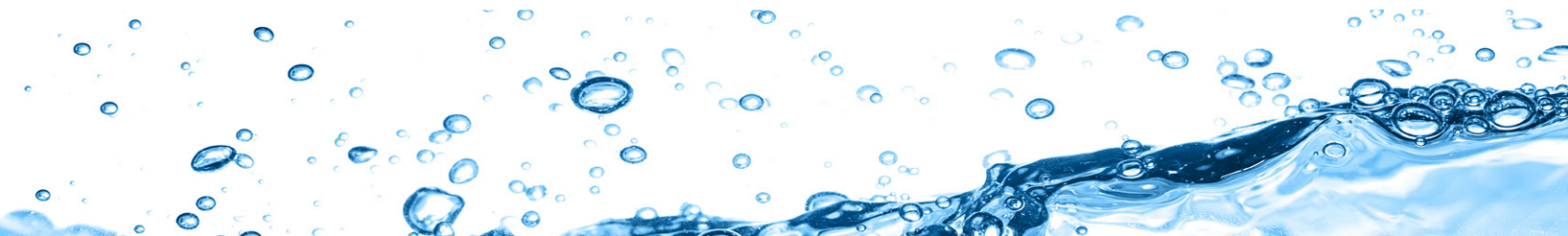

FEATURES AND TECHNICAL DATA

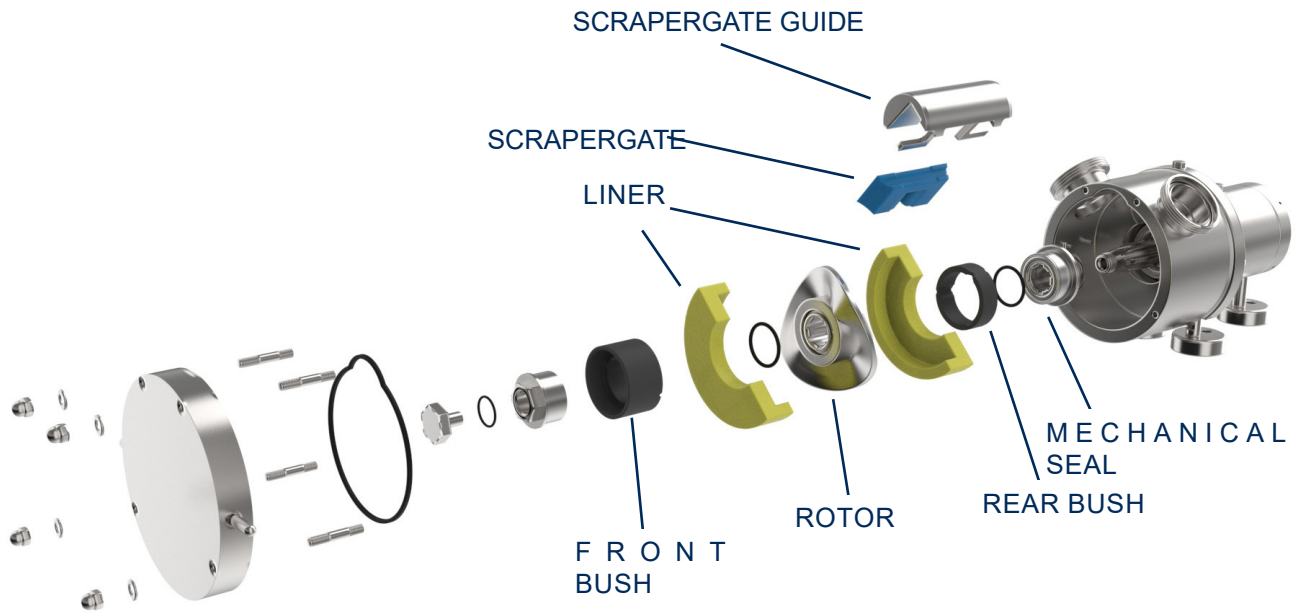

SN 65-80-100 Series

Flow rates from 0 to 36 m³/h.
 Max. pressure 15 bar.
 Suction capability up to 8 meters with wetted pump.
 Temperatures between -10° and +90°C.
 Max. product viscosity up to 1.000.000 CP.

SN 150 Series

Flow rates from 0 to 100 m³/h.
 Max pressure 5 Bar.
 Suction capability up to 7 meters with wetted pump.
 Temperatures between -10° and +90°C.
 Max. product viscosity up to 500.000 CP.

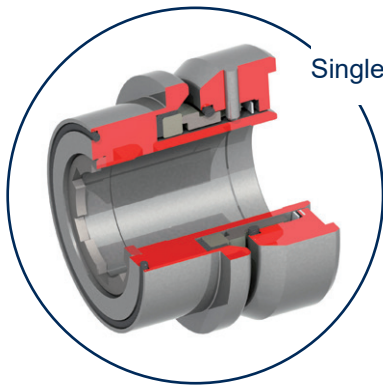

Single mechanical seal protected and bidirectional.

Connections:

DIN - SMS - IDF - BS / RJT - DS - CLAMP and EN 1092-1 PN 16 flanges suitable for all international standards.

Position of connections and rotation

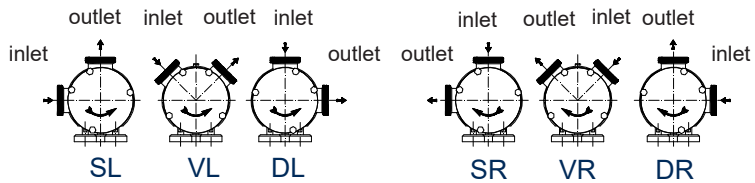

Max particle size:

SN 65 : 18 mm
 SN 80 : 25 mm
 SN100 : 35 mm
 SN150 : 36/38 mm

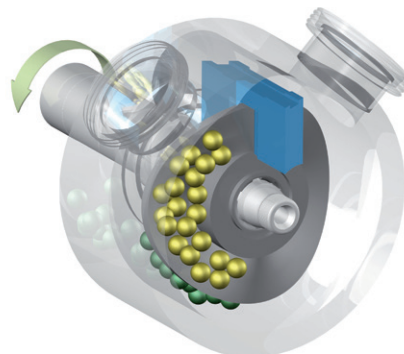

SN 65 (2 1/2") PERFORMANCE CHART

Theoretical volumetrical performance Q= 0,11 l/rev

POMPA TIPO Pump type		SN 65				Raccordi femmina DIN 11851 Connection male DIN 11851	
Rotore fino a 70°C up to 158°F	Rotore ridotto 70°C - 100°C 158°F - 212°F	Potenza minima installata Minimum installed power	Potenza massima ammisibile Maximum allowable power	Dimensione massima prodotto solido Maximum dimension of the solid product	Portata teorica a giro Theoretical revolutional delivery	Bocca aspir. Suction port DN 65	Bocca mand. Discharge port DN 65
97,9 mm	---	0,5 kW	---	18 mm	0,11 l	---	---
Eccentricità "h" Eccentricity	Eccentricità "h" Eccentricity	---	---	---	---	---	---

CARATTERISTICHE DI FUNZIONAMENTO CON ACQUA PULITA A 20°C - PESO SPECIFICO 1 (kg/dm³) - VISCOSITÀ 1 (cps)
Curves show performance with clear water at 68°F - Specific gravity 1 (kg/dm³) - Viscosity 1 (cps)

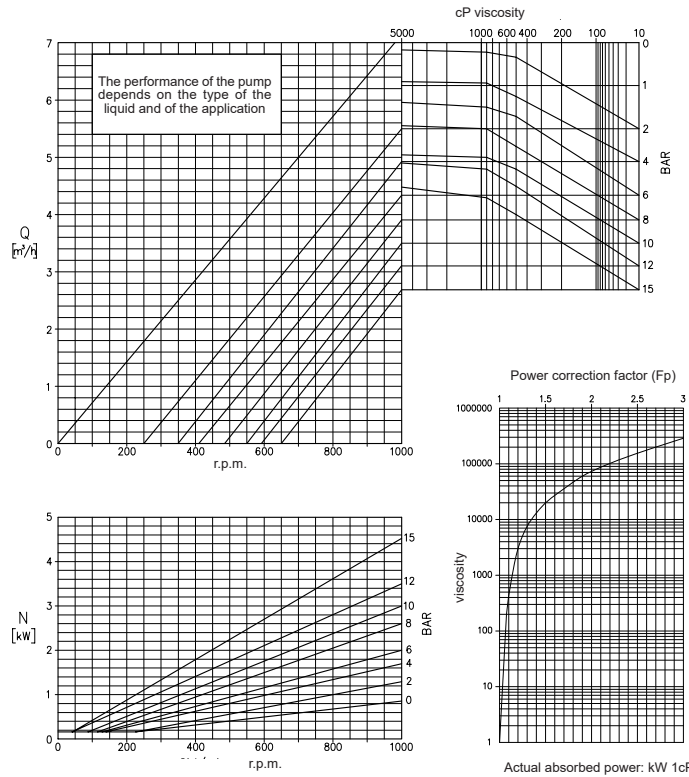

SN 80 (3") PERFORMANCE CHART

Theoretical volumetrical performance Q= 0,45 l/rev

POMPA TIPO Pump type		SN 80				Raccordi femmina DIN 11851 Connection male DIN 11851	
Rotore fino a 70°C up to 158°F	Rotore ridotto 70°C - 100°C 158°F - 212°F	Potenza minima installata Minimum installed power	Potenza massima ammisibile Maximum allowable power	Dimensione massima prodotto solido Maximum dimension of the solid product	Portata teorica a giro Theoretical revolutional delivery	Bocca aspir. Suction port DN 80	Bocca mand. Discharge port DN 80
165 mm	---	1 kW	---	25 mm	0,45 l	---	---
Eccentricità "h" Eccentricity	Eccentricità "h" Eccentricity	---	---	---	---	---	---

CARATTERISTICHE DI FUNZIONAMENTO CON ACQUA PULITA A 20°C - PESO SPECIFICO 1 (kg/dm³) - VISCOSITÀ 1 (cps)
Curves show performance with clear water at 68°F - Specific gravity 1 (kg/dm³) - Viscosity 1 (cps)

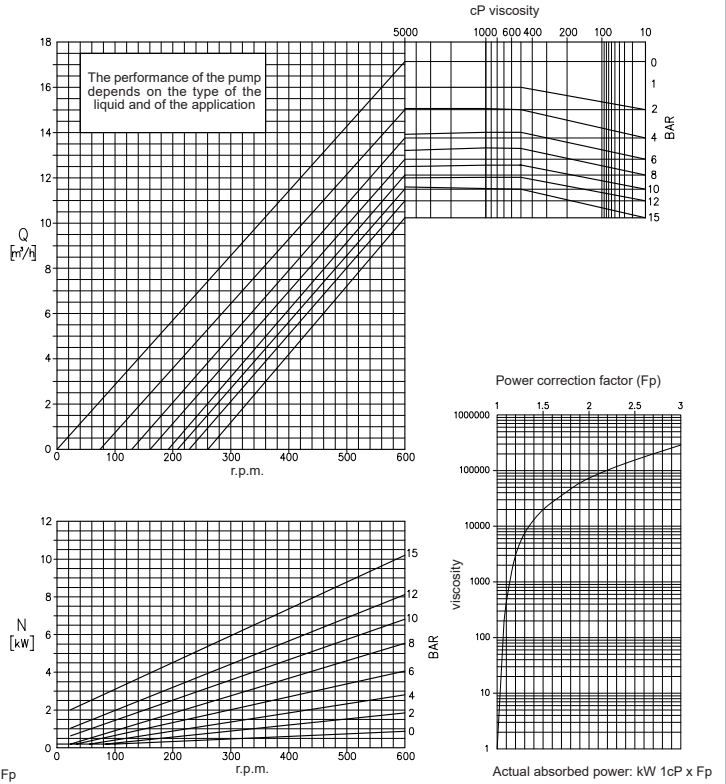

SN 100 (4") PERFORMANCE CHART

Theoretical volumetrical performance Q= 1,05 l/rev

POMPA TIPO Pump type		SN 100				Raccordi femmina DIN 11851 Connection male DIN 11851	
Rotore fino a 70°C up to 158°F	Rotore ridotto 70°C - 100°C 158°F - 212°F	Potenza minima installata Minimum installed power	Potenza massima ammisibile Maximum allowable power	Dimensione massima prodotto solido Maximum dimension of the solid product	Portata teorica a giro Theoretical revolutional delivery	Bocca aspir. Suction port DN 100	Bocca mand. Discharge port DN 100
218 mm	---	1 kW	---	35 mm	1,05 l	---	---
Eccentricità "h" Eccentricity	Eccentricità "h" Eccentricity	---	---	---	---	---	---

CARATTERISTICHE DI FUNZIONAMENTO CON ACQUA PULITA A 20°C - PESO SPECIFICO 1 (kg/dm³) - VISCOSITÀ 1 (cps)
Curves show performance with clear water at 68°F - Specific gravity 1 (kg/dm³) - Viscosity 1 (cps)

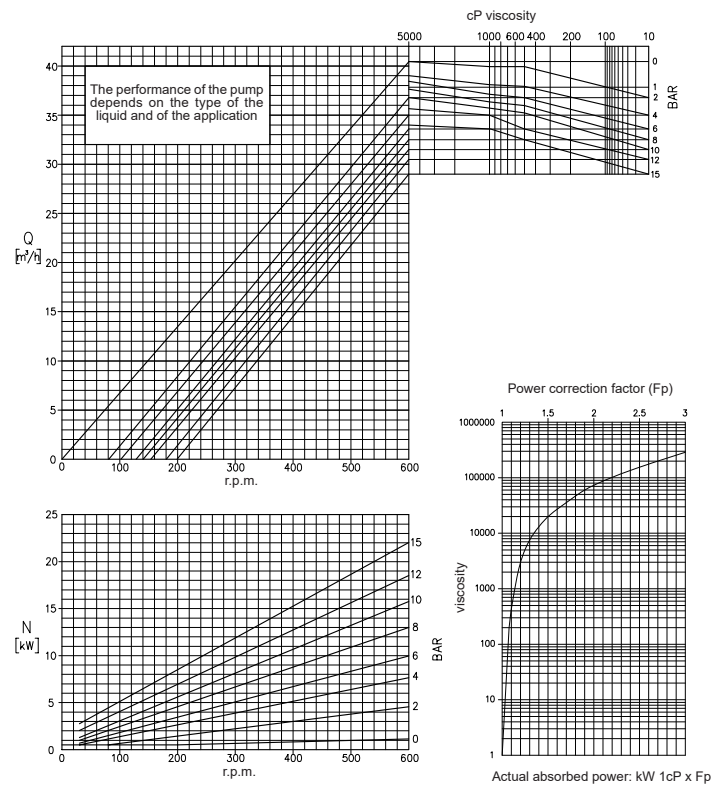

SN 150 PERFORMANCE CHART FL. DN 150

Theoretical volumetrical performance Q= 2,5 l/rev

POMPA TIPO Pump type		SN 150				Raccordi femmina DIN 11851 Connection male DIN 11851	
Rotore fino a 70°C up to 158°F	Rotore ridotto 70°C - 100°C 158°F - 212°F	Potenza minima installata Minimum installed power	Potenza massima ammisibile Maximum allowable power	Dimensione massima prodotto solido Maximum dimension of the solid product	Portata teorica a giro Theoretical revolutional delivery	Bocca aspir. Suction port DN 150	Bocca mand. Discharge port DN 150
270 mm	---	11 kW	---	40 mm	2,5 l	---	---
Eccentricità "h" Eccentricity	Eccentricità "h" Eccentricity	---	---	---	---	---	---

CARATTERISTICHE DI FUNZIONAMENTO CON ACQUA PULITA A 20°C - PESO SPECIFICO 1 (kg/dm³) - VISCOSITÀ 1 (cps)
Curves show performance with clear water at 68°F - Specific gravity 1 (kg/dm³) - Viscosity 1 (cps)

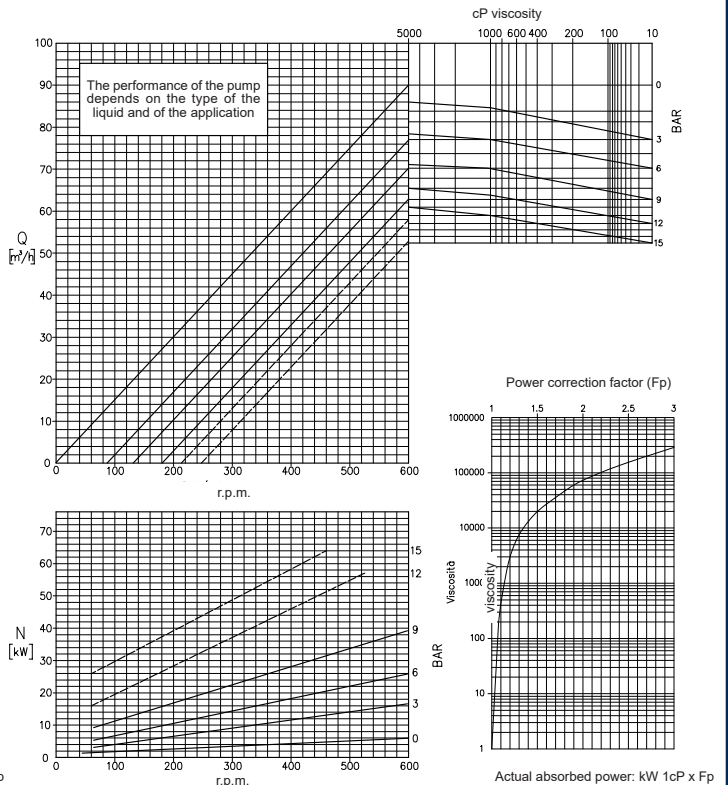

OVERALL DIMENSIONS

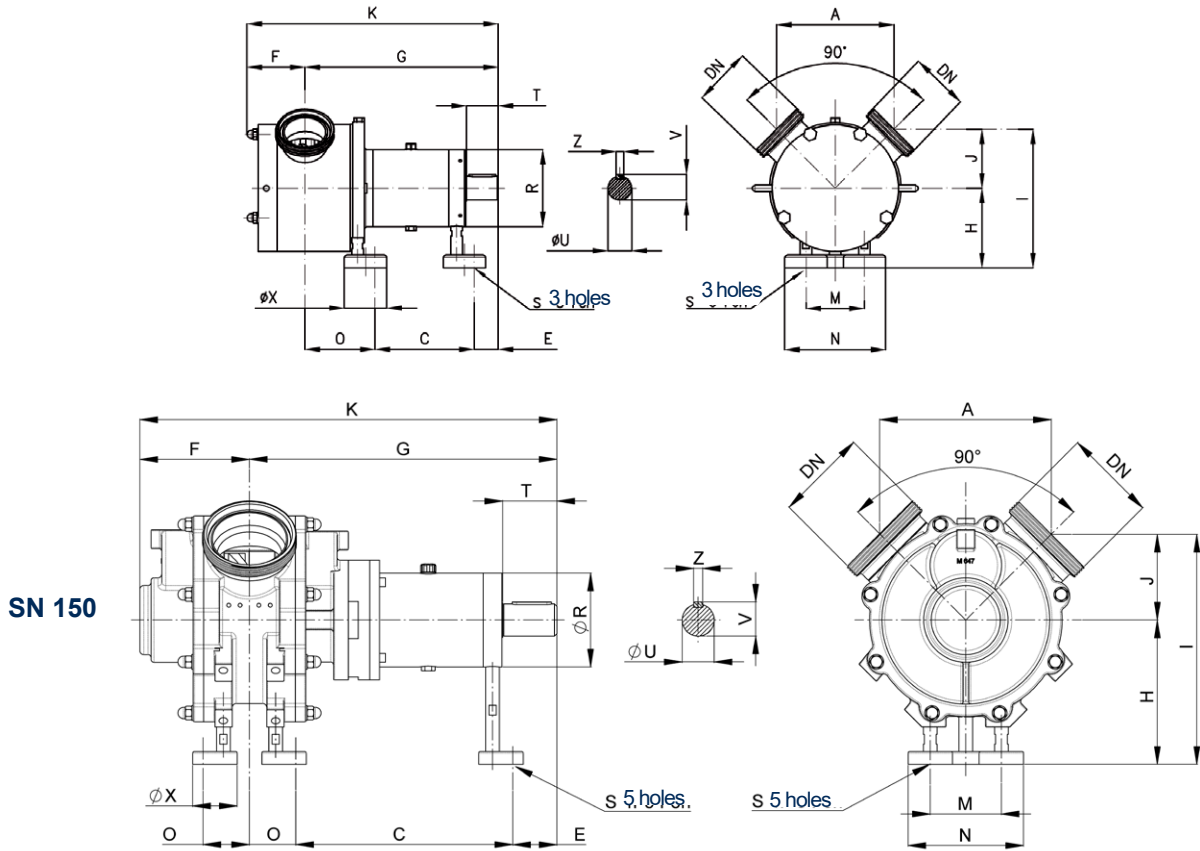

	Pump type			
	SN 65	SN 80	SN 100	SN 150
A	150	221	263	348
C	117	186	247	439
E	37	45.5	69	90
F	81	109	132.5	222
G	251	363.5	463	623
H	95	150	195	292
K	332	472.5	596.5	845
J	68	110.5	139	173
I	163	260.5	334	465
M	56	110	160	144
N	106	190	240	234
O	97	132	147	94
R	100	145	190	190
S	12	16	16	21
T	50	60	80	110
U	28	45	50	65
V	31	48.5	53.5	69
X	50	80	80	90
Z	8	14	14	18
DN DIN 11851	65	80	100	150
DN SMS	2"1/2	3"	4"	-
DN RJT	2"1/2	3"	4"	-
DN Clamp	2"1/2	3"	4"	-
DN Flange PN16	65	80	100	150
Peso	21,5	75,5	138	245



C.S.F. Inox S.p.A. Strada per Bibbiano, 7 - 42027 Montecchio E. (RE) - ITALY EU

Ph +39.0522.869911 r.a. - Fx +39.0522.865454 - italia@csf.it - www.csf.it

Export Department • Commercial Étranger • Comercial Extranjero

Ph +39.0522.869922 - Fx +39.0522.869841 - export@csf.it - www.csf.it



All the instructions, data and representations (in whatever way executed) listed in this publication are indicative and do not bind. C.S.F. does not stand surety or undertake any obligation for the utilisation of this document and for the information contained. In particular, it does not guarantee against omissions or errors of the data and drawings here indicated. Notice that the technical specifications, information and representations in this document are merely indicative and approximate. C.S.F. INOX reserves the right at any moment and without notice to modify the data, drawings and information indicated in this document.